

tedee GO

INSTALLATION GUIDE AND USER MANUAL

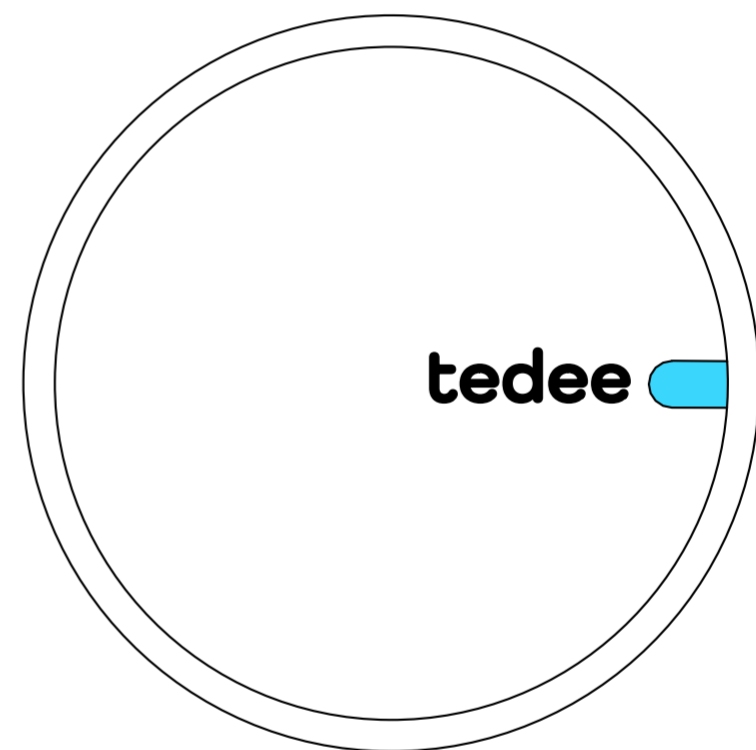
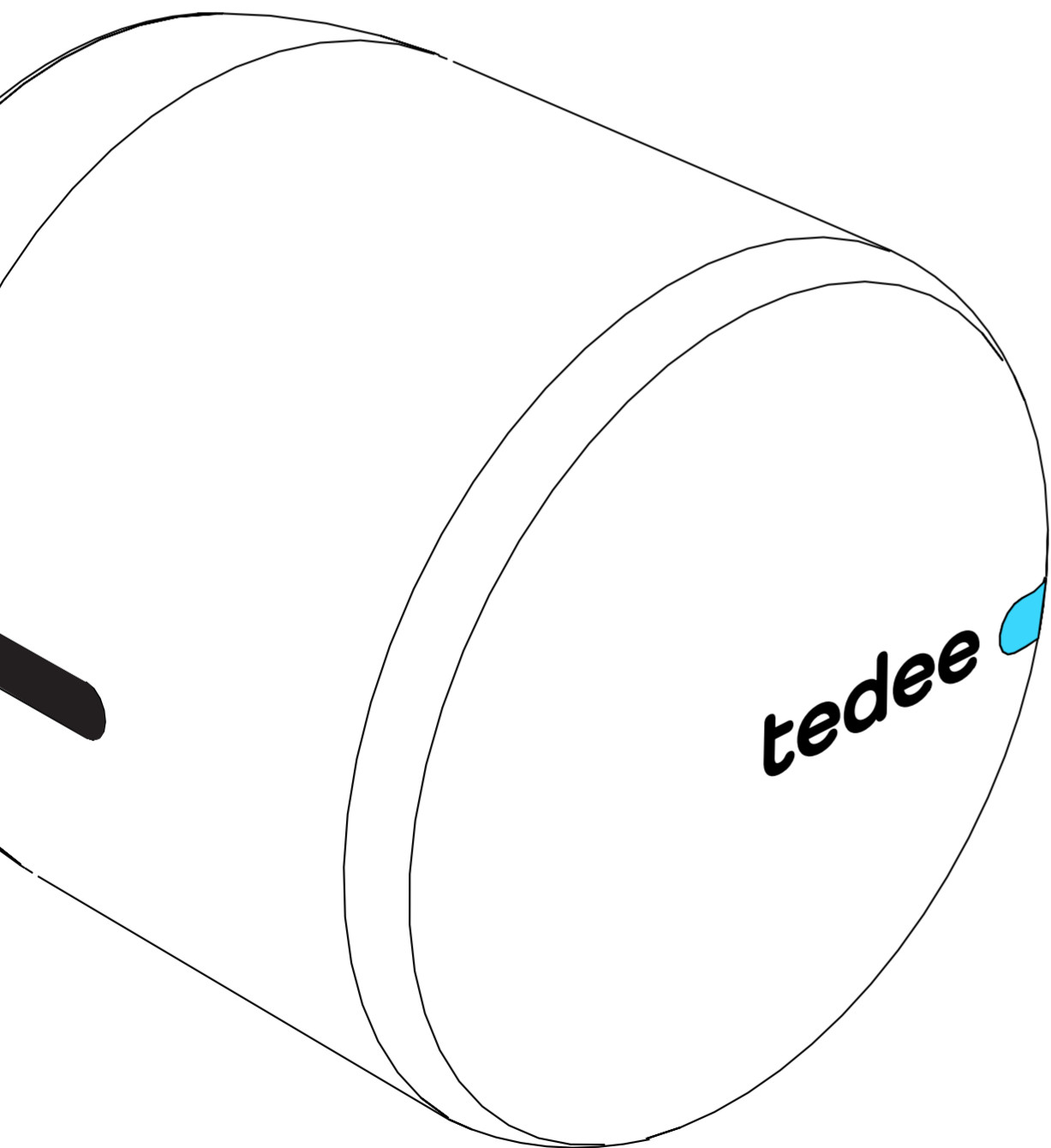

Read installation guide and user manual. Learn how to use your device in a safe and proper manner.

CONTENT

3 QUICK START WITH TEDEE GO

4 SAFETY INFORMATION

4 | safety guidelines / warnings

5 | charging and maintenance guidelines / warnings

7 SET OF ITEMS - WHAT'S IN THE BOX?

8 ACTIVATION CODE

9 SETUP - 5 EASY INSTALLATION STEPS

9 | step 1: INSTALL ADAPTER (OPTIONAL)

11 | step 2: INSTALL TEDEE GO

13 | step 3: REMOVE BATTERY PROTECTIVE TABS

14 | step 4: DOWNLOAD THE TEDEE APP, CREATE A NEW ACCOUNT AND LOG IN

15 | step 5: USE THE TEDEE APP TO ACTIVATE AND CALIBRATE YOUR TEDEE GO LOCK

16 DEINSTALLATION OF TEDEE GO

18 BATTERY REPLACEMENT

19 FACTORY RESET

20 ADDITIONAL AND TECHNICAL INFORMATION

20 | technical specifications

21 | radio frequency

21 | software

22 | LED signals

24 | legal / environmental notes

24 | warranty

25 | technical support

QUICK START WITH TEDEE GO

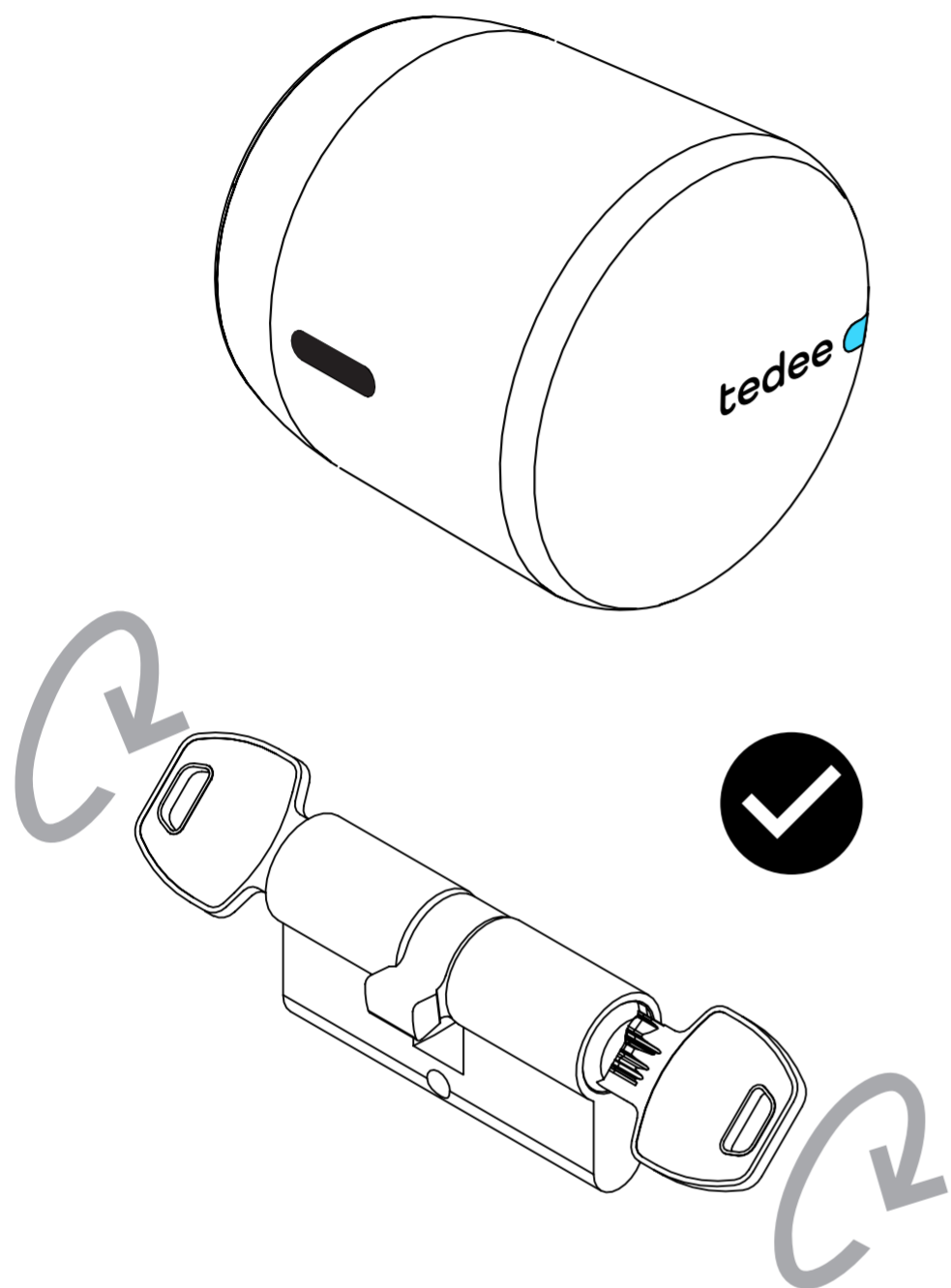

Tedee GO is a smart door lock that can be fitted to any euro-profile cylinder, with a double-clutch (panic function) feature.

Tedee GO allows you to unlock the door, share access, and check all activities remotely.

This manual will give you an overview of the basic features of Tedee lock and will help you walk through the setup in five easy steps.



ATTENTION: Tedee GO is only compatible with euro profile cylinders equipped with a double clutch function (panic function), allowing the door to be unlocked from both sides with a key, with both keys inserted in the cylinder, as shown in the figure on the left.



If you are unable to determine whether your cylinder has a double-clutch function, please contact Tedee support.

TEDEE GO SETUP - GO TO PAGE 9

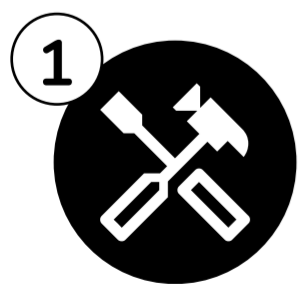

1
INSTALL
ADAPTER
(OPTIONAL)

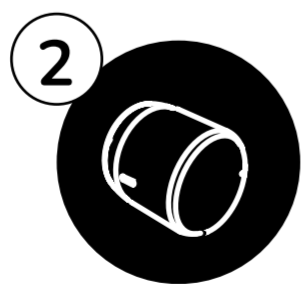

2
INSTALL TEDEE
GO

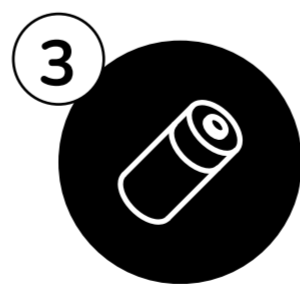

3
REMOVE BATTERY
TABS

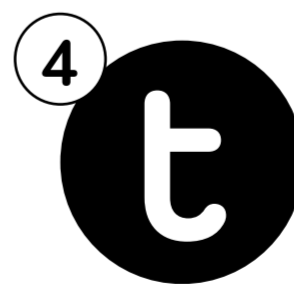

4
GET
TEDEE APP

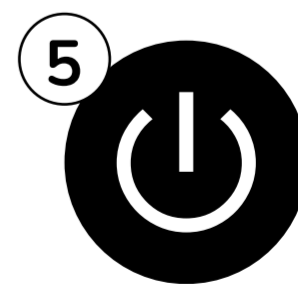

5
ACTIVATE
AND CALIBRATE
YOUR LOCK

SAFETY INFORMATION



WARNING: Read all safety guidelines and warnings provided below. Failure to follow them may result in electric shock, fire, and / or serious injury.

SAFETY GUIDELINES / WARNINGS

DO NOT

- Do not modify or disassemble the device, except as provided in the instructions (battery replacement/removal of protective tabs).
- Do not self-service any part of the device.
- Do not use outdoors, intended for indoor use only.
- Do not immerse the device in any liquid or expose it to moisture.
- Do not use the device near an extreme heat source or open fire.
- Do not use the device in an environment of a high humidity or dust levels, as well as pollution degree II.
- Do not insert any conductive objects in device openings and gaps.
- The appliance is not to be used by persons (including children) with reduced physical, sensory or mental capabilities, or lack of experience and knowledge, unless they have been given supervision or instruction. Children should be supervised not to play with the appliance.
- The device cannot be used as the only mean of access control to rooms or premises that require increased access control.

DO

- If repairs are required, please contact Tedee technical support.
- Use only the batteries provided or recommended by Tedee.
- Read the installation guide and learn how to start working with your lock, how to add it to your Tedee app and how to pair it with other Tedee devices. You can also follow the link: <https://tedee.com/support-3/manuals/>

MOVING PARTS

- Because you can operate the device remotely, it is not recommended to keep your hands on the housing.

Battery-powered Tedee GO lock includes non-rechargeable and non-user-serviceable batteries.

DO NOT

- Do not mix old and new batteries.
- Do not touch leaking batteries.
- Do not short circuit batteries or insert them incorrectly.
- Do not use batteries that appear to be leaking, discolored, rusty, deformed; emit an odor; or are otherwise abnormal.
- Do not expose the batteries to fire or high temperature. Do not leave or store batteries in hot places such as near an oven, stove, direct sunlight, or other heat sources.
- Do not immerse batteries in water or allow them to come into contact with water.
- Do not disassemble, puncture, modify, drop, throw, or cause other unnecessary shocks to batteries.
- Do not place batteries in a microwave oven, or into any other high-pressure container.
- Do not carry loose batteries in a pocket or purse with other metal objects.
- Do not charge the non-rechargeable batteries included in your Tedee GO set. Do not overcharge rechargeable batteries (if applicable).
- Do not put batteries in the mouth and do not swallow them. If swallowed, contact your local medical help immediately.
- Neither Tedee Sp. z o.o. nor our retailers assume any liability for failures to comply with these warnings and safety guidelines. By purchasing this device, the buyer assumes all risks associated with LiPo batteries. If you do not agree with these conditions, return the device immediately before use.

RECOMMENDED BATTERIES

To power your Tedee GO lock, you need to use 3x CR-123/123A batteries or 3x CR-123 rechargeable batteries. We only allow to use 3V CR123/123A batteries or 3.7V CR123 rechargeable batteries.



WARNING: You can permanently damage the device while trying to use or install the batteries or rechargeable batteries exceeding 3/3.7V respectively.

DO

- Do read the instructions for batteries replacement provided in this booklet.
 - Do insert new batteries correctly, following the symbols for positioning the positive (+) and negative (-) terminals of each battery. Do not reverse battery polarity.
 - Do use only one type of batteries when replacing batteries in the device (do not mix).
 - Do replace batteries with the size and type specified in this manual. Always replace all batteries in Tedee GO at the same time.
 - Do store batteries in a cool, dry place at normal room temperature.
 - Do remove batteries from devices that will be unused for extended periods of time.
 - Do segregate, recycle, and dispose of the batteries according to your local regulations. For more information contact your local authority.
-

Other information

- The cleansing pad included with the device contains highly flammable isopropyl alcohol, which may cause serious eye irritation and drowsiness or dizziness if inhaled. Keep it away from direct heat/fire/ignition sources and avoid contact with eyes or inhalation. Wash hands with soap after use. If eye irritation occurs, rinse carefully with water. If inhaled, go out into the fresh air and make breathing comfortable. Seek medical advice if irritation/breathing problems persist.
- Dispose the devices in accordance with your local regulations. If possible, recycle.
- Do not dispose the device as a household waste and do not burn it.
- This device is safe to use under normal and reasonably foreseeable misuse operating code of conduct. If you notice any signs of errors or hardware malfunction, contact Tedee technical support for help. In such case this device should be returned to Tedee for necessary repairs under the warranty conditions. Any changes or modifications to the device's hardware or software which are not approved, recommended, or provided by Tedee may void your warranty.
- Neither Tedee Sp. z o. o., nor our retailers are responsible for failure to comply with the above warnings and safety guidelines. By purchasing this device, the buyer acknowledges all risks associated with the use of Tedee equipment. If you do not agree to these terms, return the device to the manufacturer or distributor before use.

SET OF ITEMS – WHAT'S IN THE BOX?

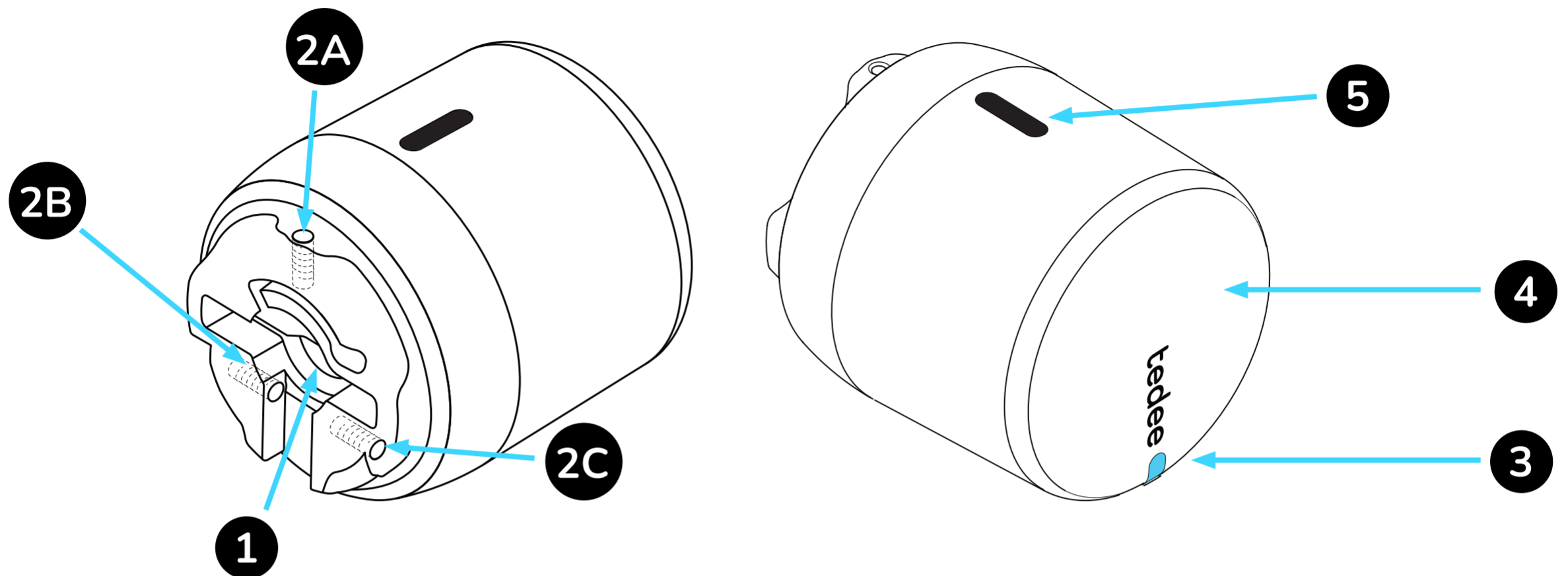

- | | | |
|---------------------------------|--|---|
| 1. Key bow hole | 4. The button | 7. Adapter (for fixing with an adhesive tape) |
| 2. Mounting screws (2A, 2B, 2C) | 5. Latch button (press to slide off the cover) | 8. Allen key size 2 |
| 3. LED | 6. 3x CR123 batteries | 9. Cleansing wipe pad |

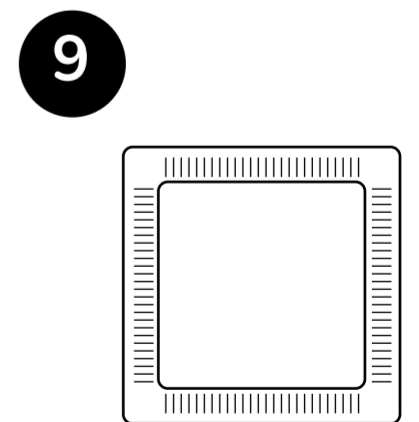
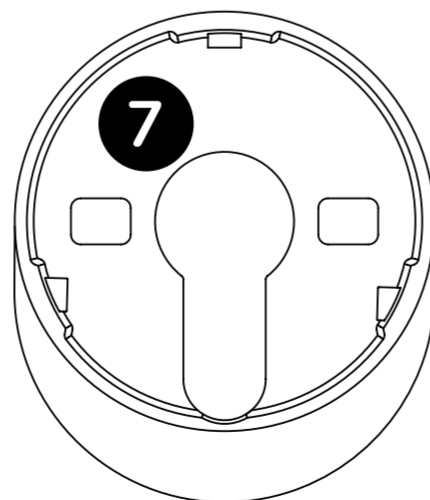
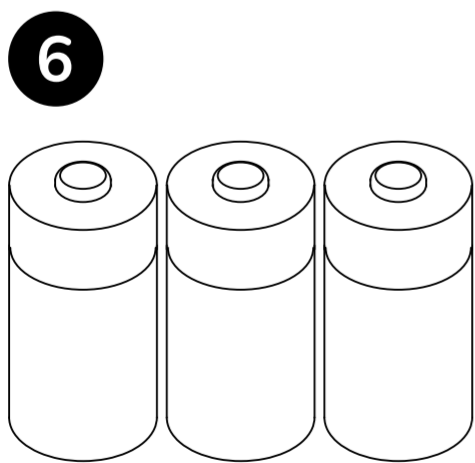

ACTIVATION CODE

Location of the unique activation code (AC) of your Tedee lock.

Activation code (AC) of your Tedee lock is printed on:

SEPARATE STICKER INCLUDED IN THE KIT

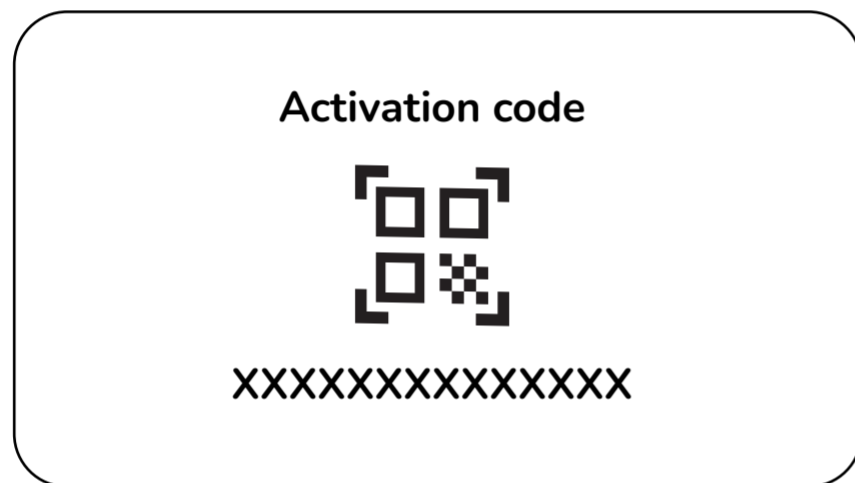

FRONT SIDE OF YOUR DEVICE

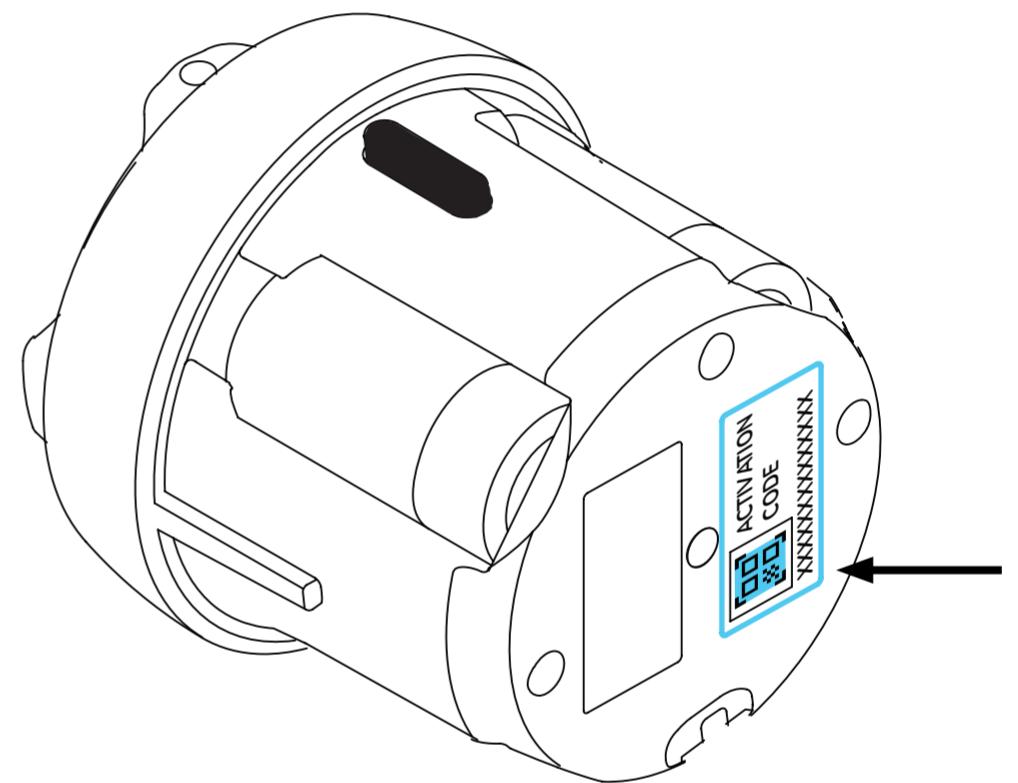

While adding your device to Tedee app you can either:

- scan the QR Code
- type in AC manually (14 characters)



HELPFUL TIP

Before fitting the Tedee lock to the cylinder, take a photo of your activation code and keep it.

SETUP - 5 EASY STEPS

STEP 1: INSTALL ADAPTER (OPTIONAL)

ATTENTION: If your lock cylinder extends **less** than 3mm beyond the rosette/escutcheon, as shown in the picture below, follow the steps for fitting the adapter shown on the next page of the manual.

If your cylinder extends **3mm or more** beyond the outline of the door, go straight to STEP 2: INSTALL TEDEE GO.

ADAPTER NEEDED

Follow the instructions below

< 3 mm

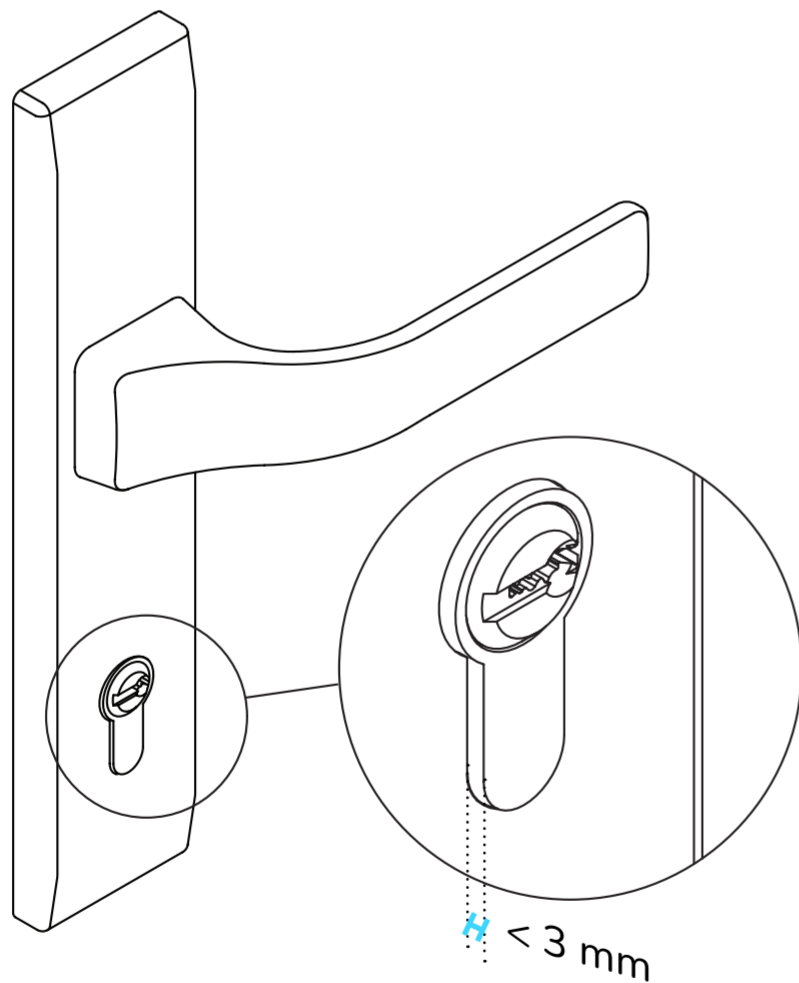

ADAPTER NOT NEEDED

Proceed to step 2

>= 3 mm

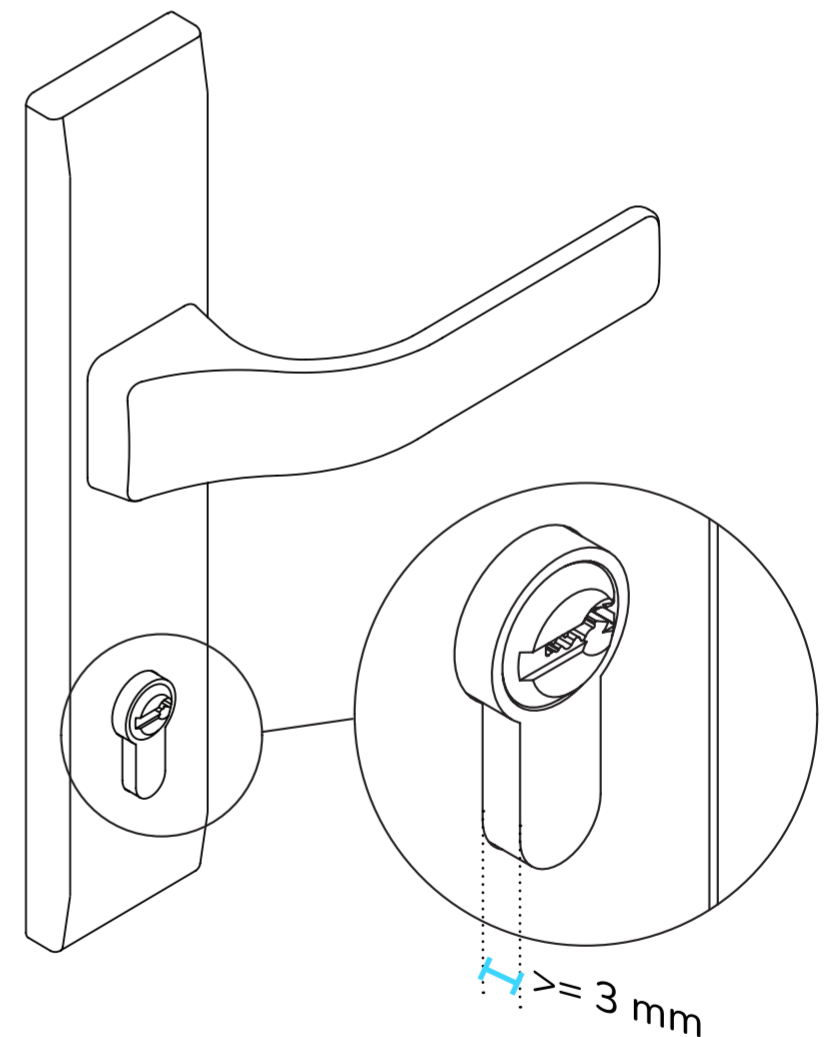

USE THE RULER PROVIDED WITH THE TEDEE GO SET TO TAKE MEASUREMENTS.

- 1** Thoroughly wipe the area around the lock cylinder (rosette/escutcheon) with the cleansing wipe pad provided and let it dry for about 1 minute.

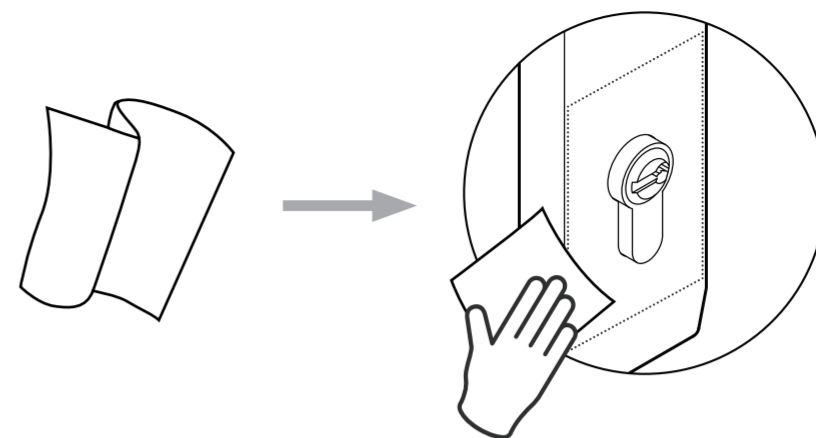

- 2** Carefully remove the protective film from the back of the adapter, taking care not to touch the adhesive tape, which may weaken its properties.

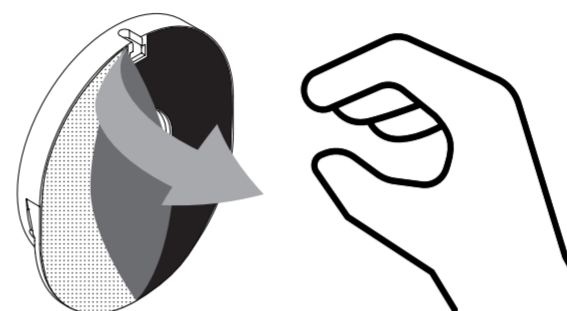

- 3** Mount the adapter around the cylinder as shown below, making sure that the adhesive does not come into contact with the cylinder, then press the adapter firmly against the door for 1 minute. You can now insert the key into the cylinder.

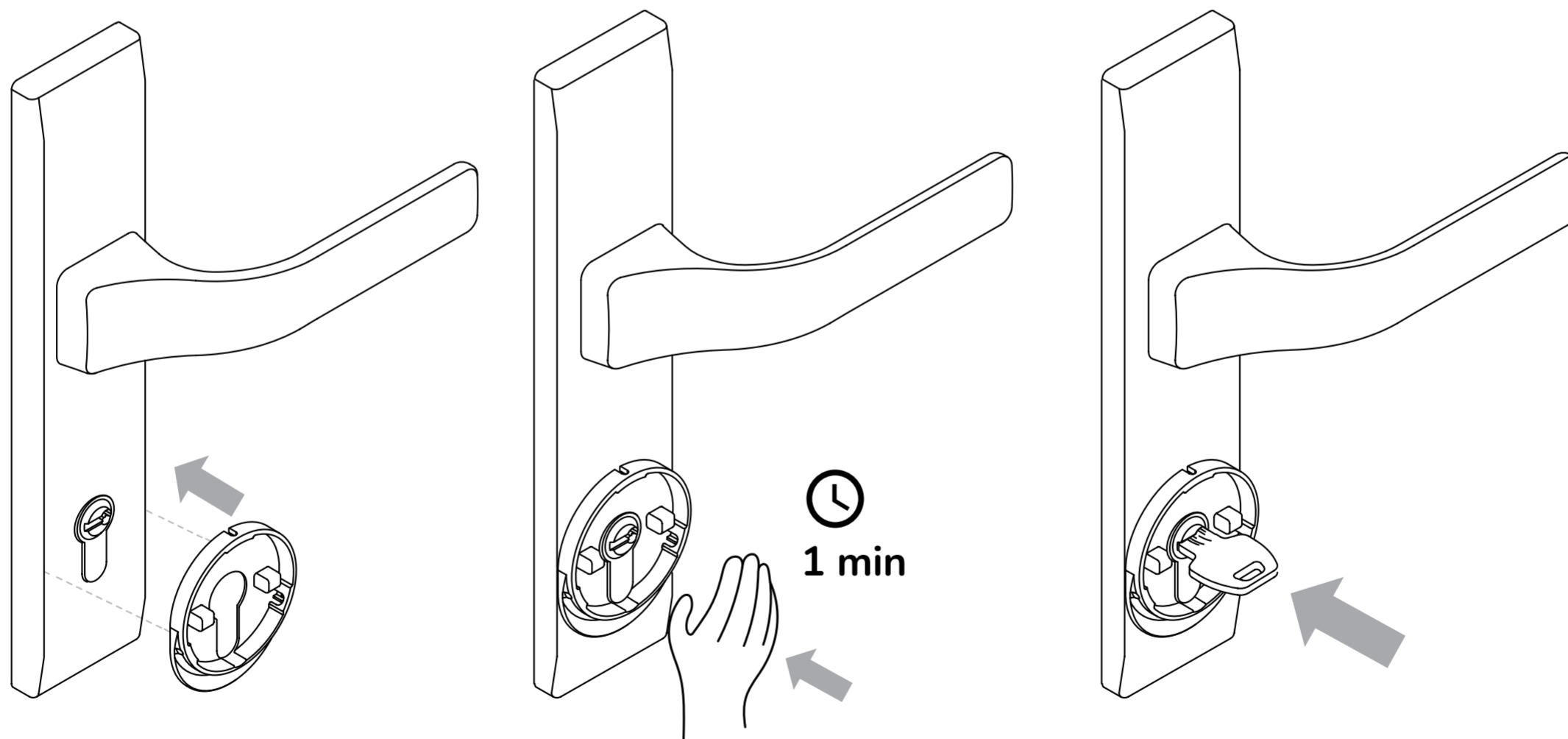

Note: Make sure you install the adapter in a room with a temperature above 15 degrees Celcius.

STEP 2: INSTALL TEDEE GO

1

Position the key horizontally and make sure that the housing latch button faces upwards (vertically), as shown below.

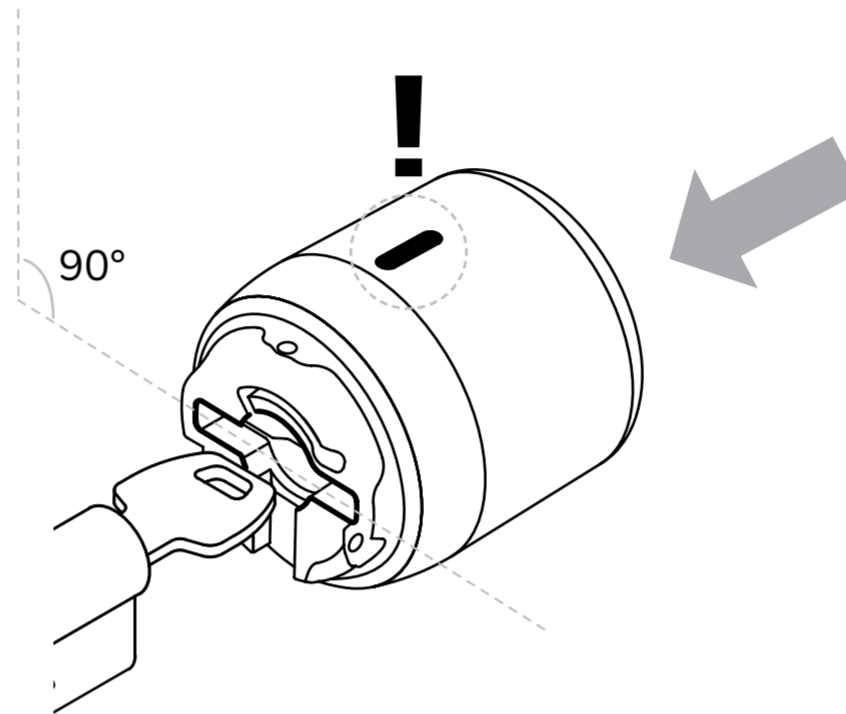

2

Slide Tedee GO lock onto the cylinder until you feel resistance.

WITH THE ADAPTER

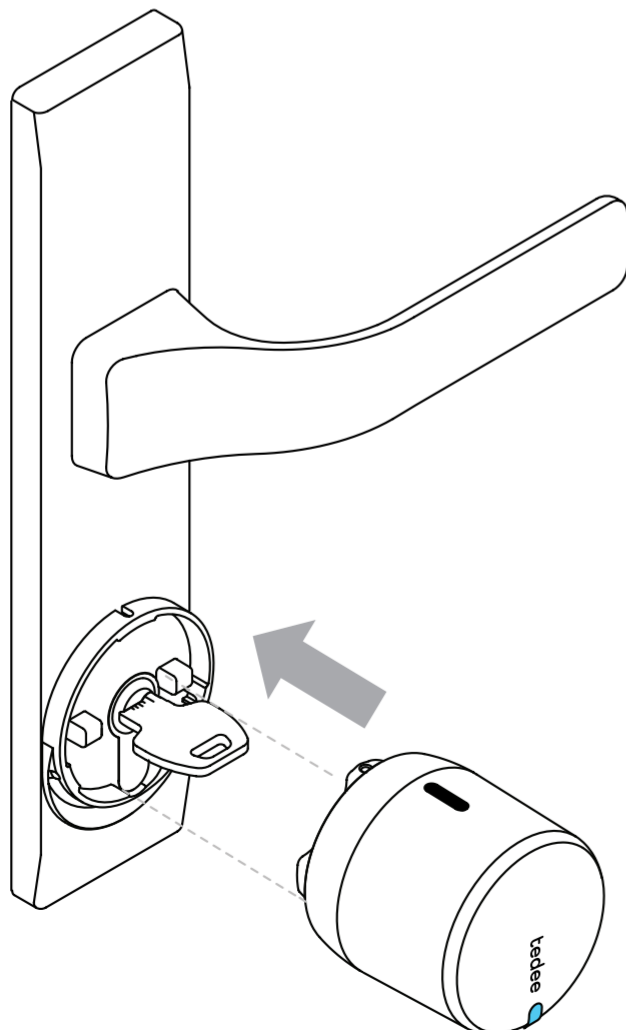

WITHOUT THE ADAPTER

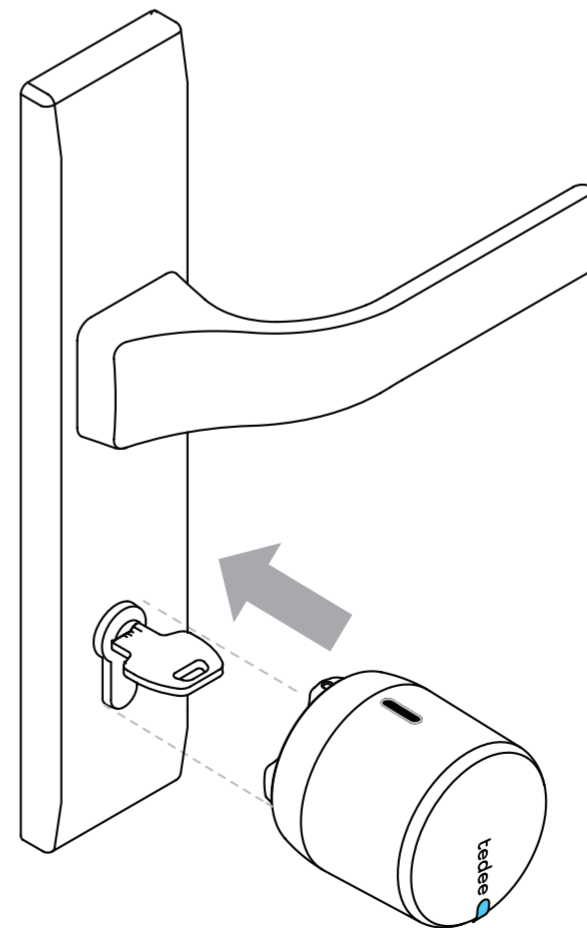

- 3** While **continuously** pushing the Tedee GO lock firmly against the door, use the provided allen key, to fix all three mounting screws (A, B, C), starting from the top (A), in the order shown below, until you encounter a firm resistance.

WITH THE ADAPTER

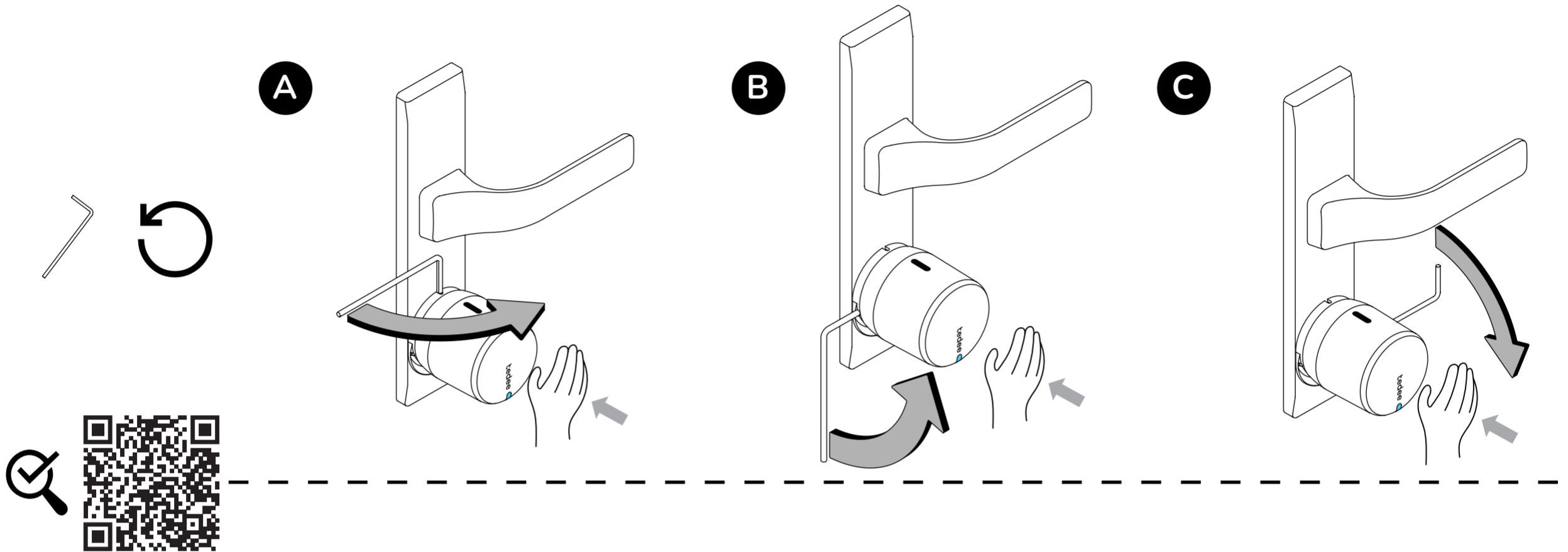

WITHOUT THE ADAPTER

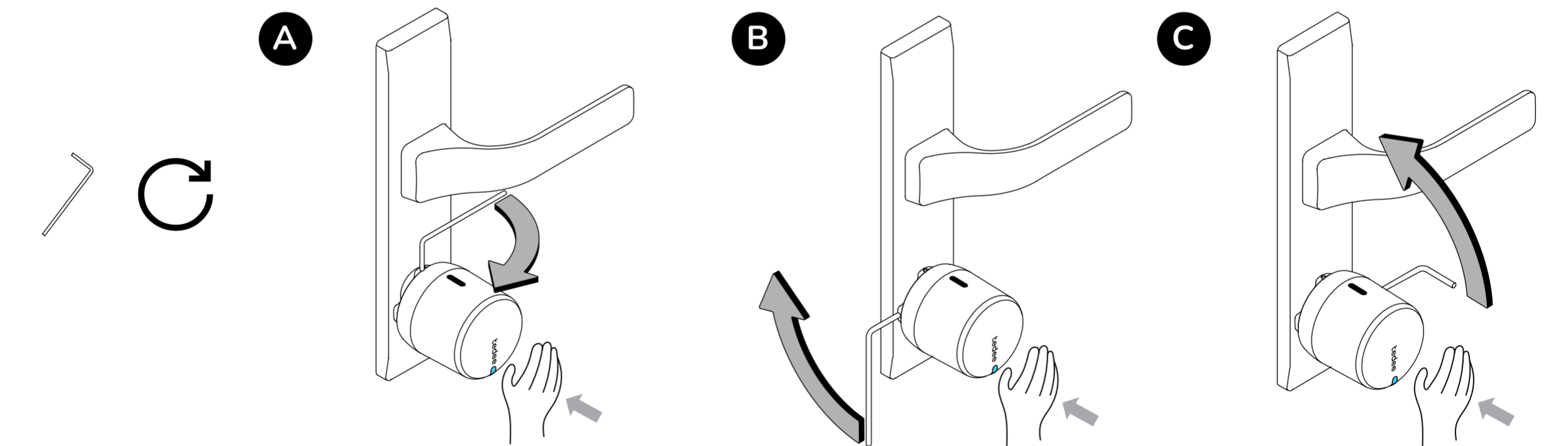

Attention: Make sure to keep pushing the lock towards the door while fixing the screws. If you don't, the installation may not succeed and you may need to repeat this step.

STEP 3: UNLOCK BATTERIES

1

Keep the latch button pressed while sliding off the cover.

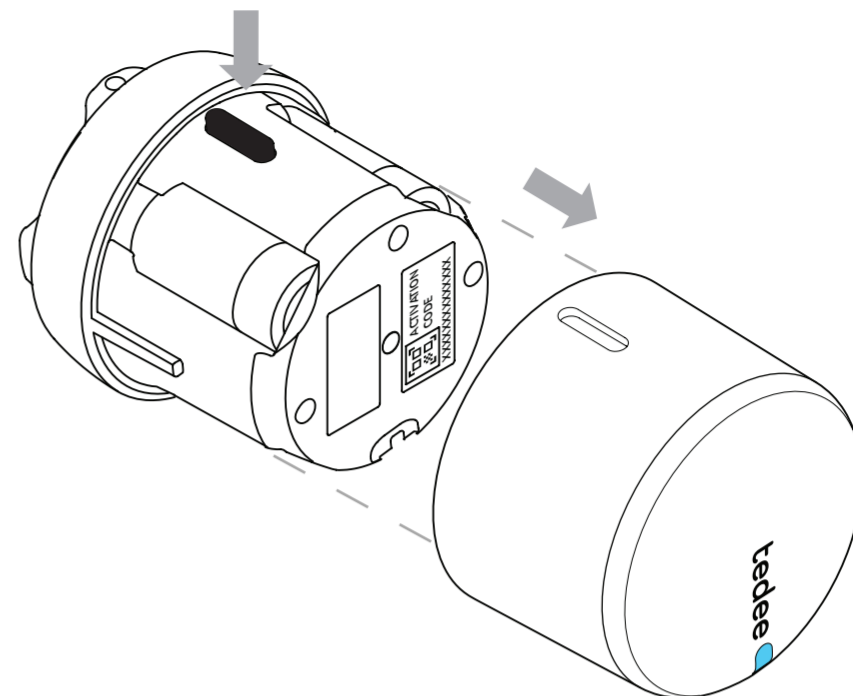

2

Remove the protective tabs from under all three batteries.

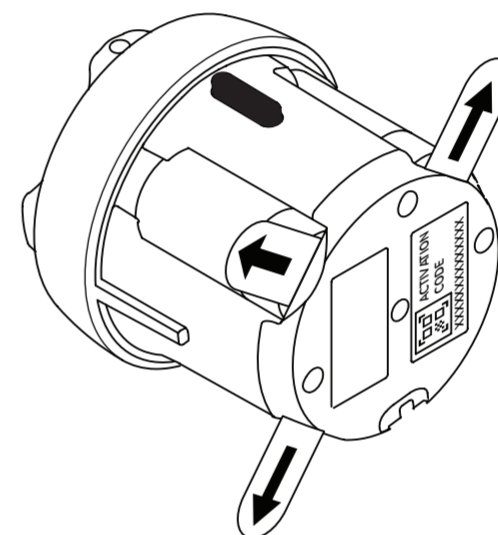

3

After removing the third protective tab, check for a light signal (LED). The RED-GREEN-BLUE-WHITE sequence confirms that your Tedee GO is ready.

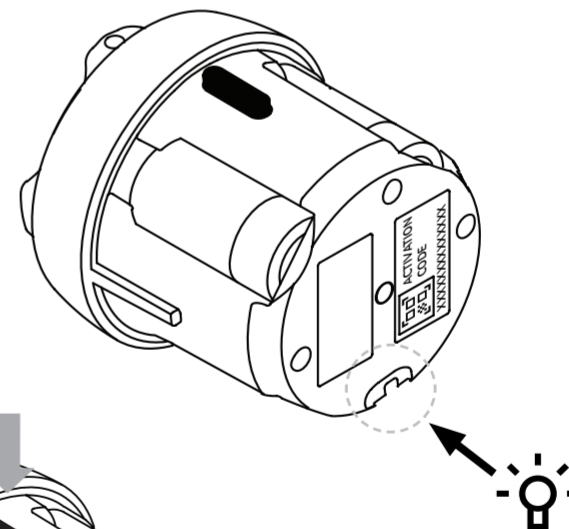

4

Slide the cover back onto the housing, holding down the latch button until it clicks into place.

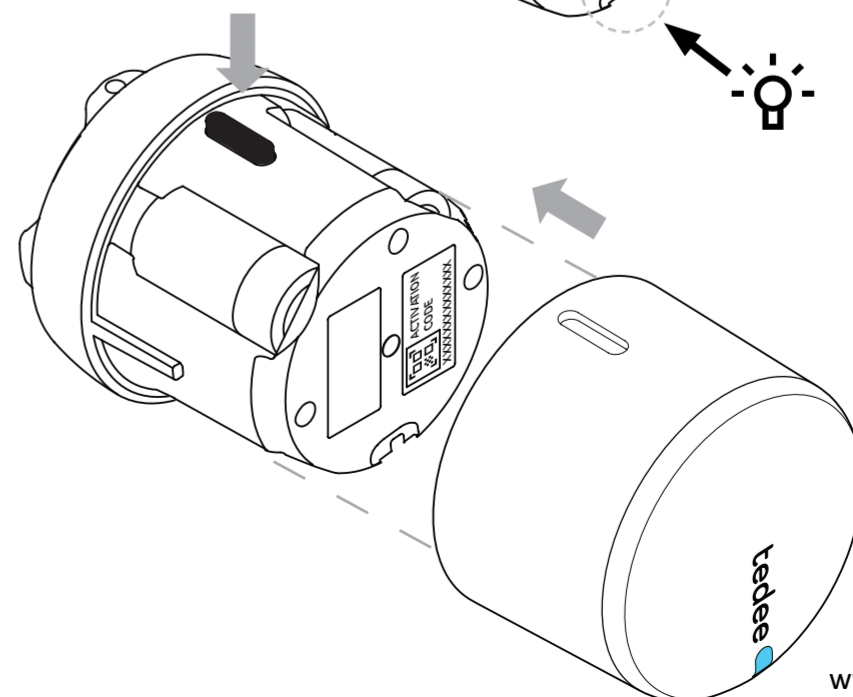

You can now add and calibrate your Tedee GO lock in the Tedee app.

STEP 4: DOWNLOAD THE TEDEE APP, CREATE A NEW ACCOUNT, AND LOG IN

(SKIP THIS STEP IF YOU ALREADY HAVE AN ACCOUNT)

1 Download Tedee application.

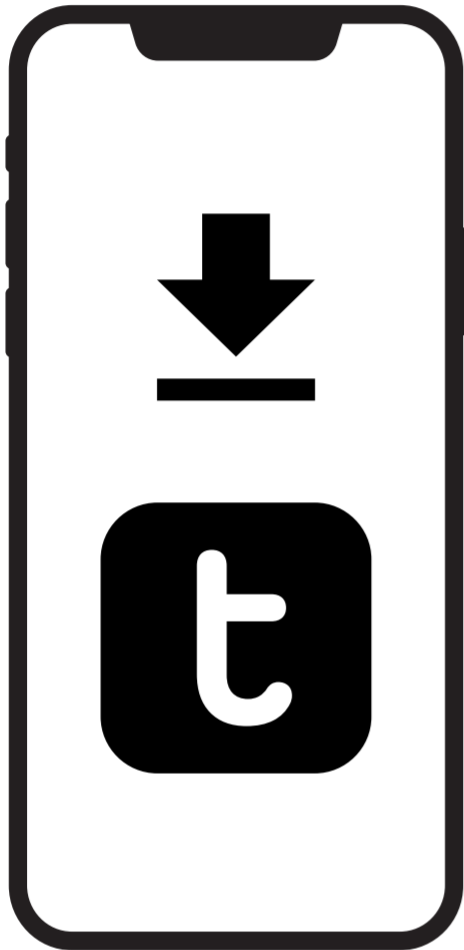

2 Create an account or log in to an existing account.

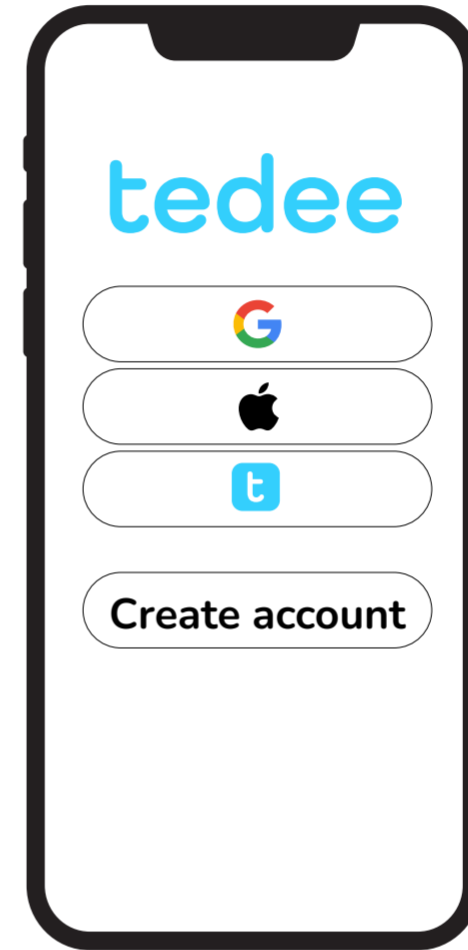

The registration page will open

Android* v. 8+	iOS* v. 15+
Internet & Bluetooth® min. 4.0	Internet & Bluetooth® min. 4.0

* Tedee does not guarantee continued future support for older, discontinued versions of Android/iOS software.



STEP 5: USE TEDEE APP TO ACTIVATE AND CALIBRATE YOUR TEDEE LOCK

- 1** Enable Internet connection, Bluetooth®, and location services (optional) on your smartphone.

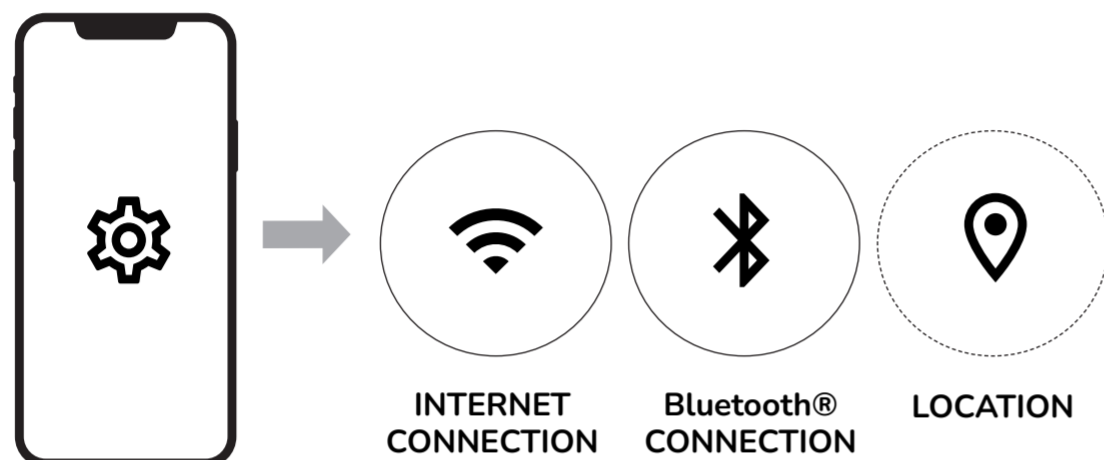

- 2** Log into the Tedee application and select the 'ADD NEW DEVICE' option from the menu.

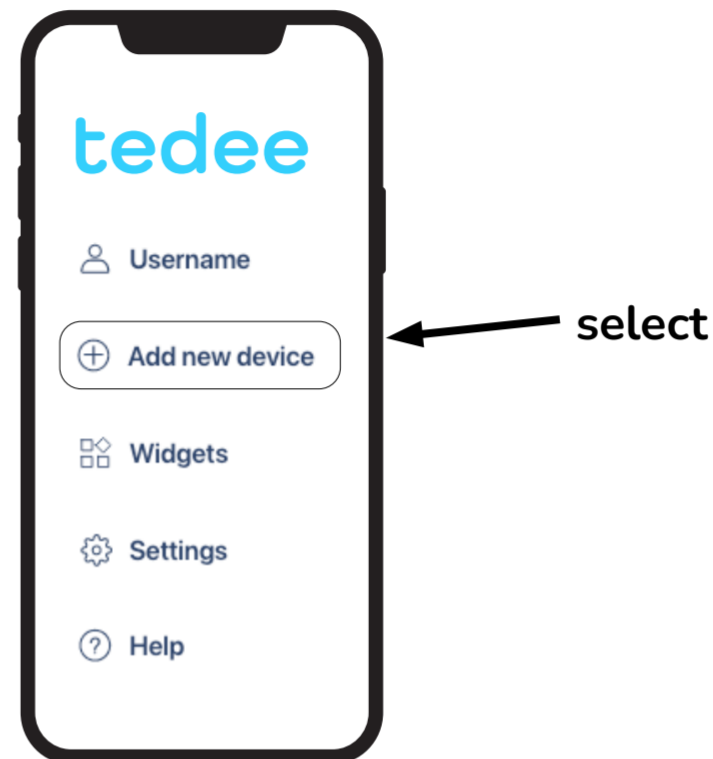

- 3** Select 'ADD DEVICE' in the lock section.

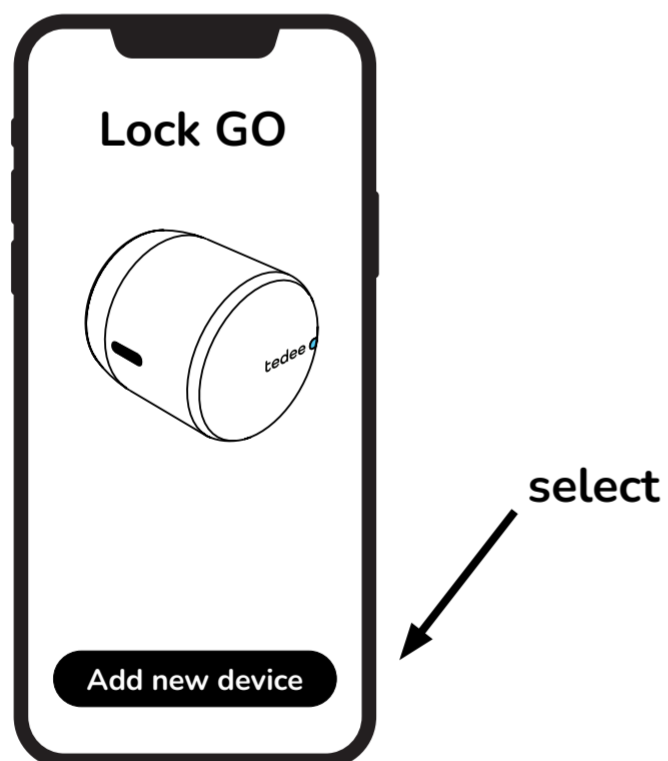

- 4** Provide activation code (AC) of your Tedee GO.



Note: after scanning the QR code or typing in the AC manually follow the instructions in the app.

DEINSTALLATION OF TEDEE LOCK

1

WITH THE ADAPTER

Rotate the allen key clockwise for all three clamping screws (A, B and C).

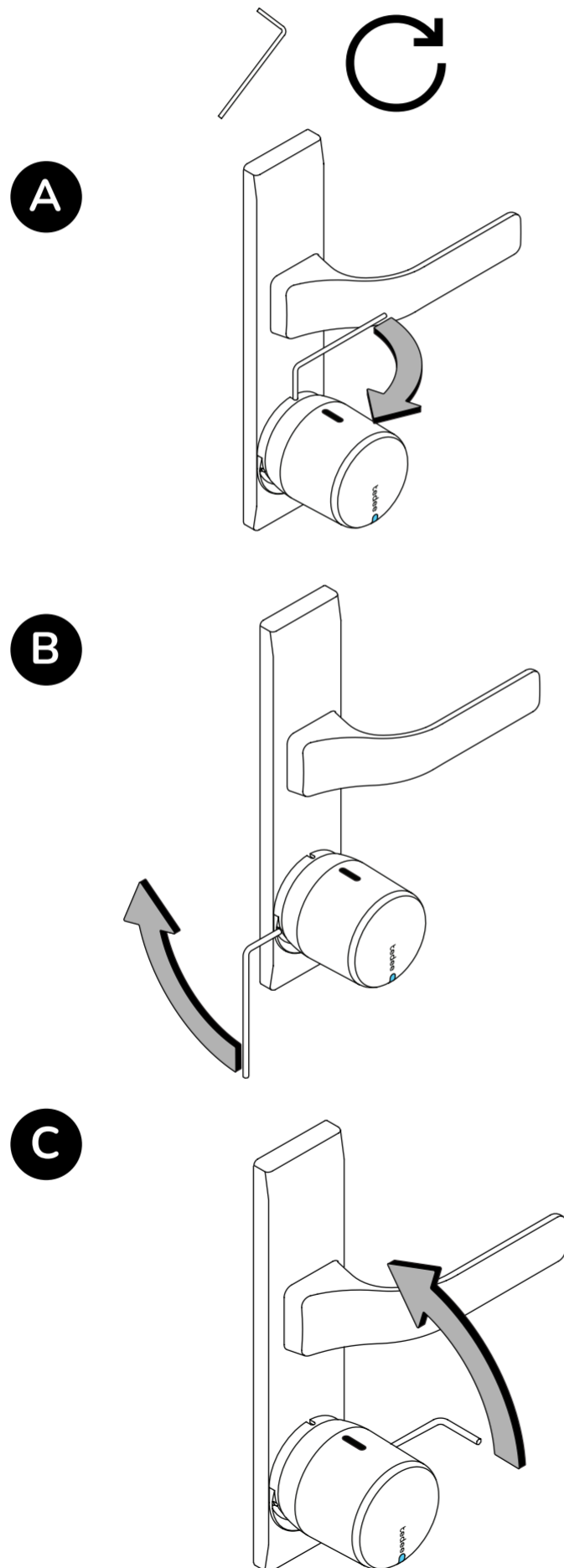

WITHOUT THE ADAPTER

Rotate the allen key counter-clockwise for all three clamping screws (A, B and C).

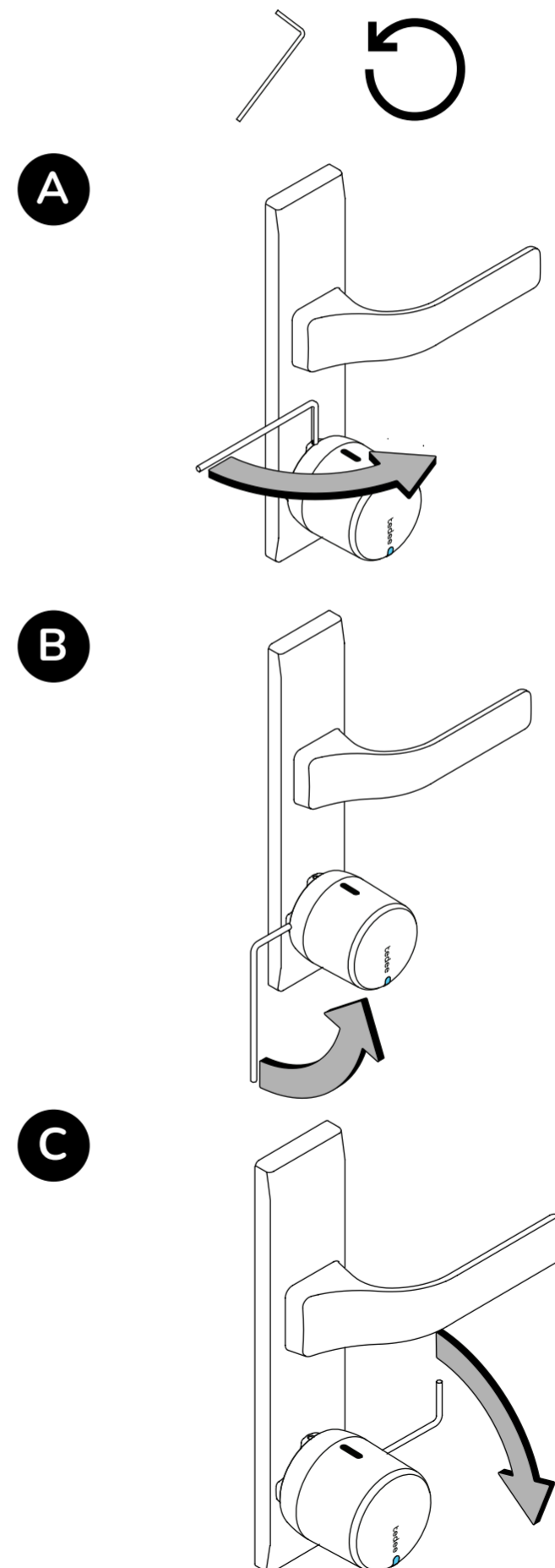

2

Pull the lock off.

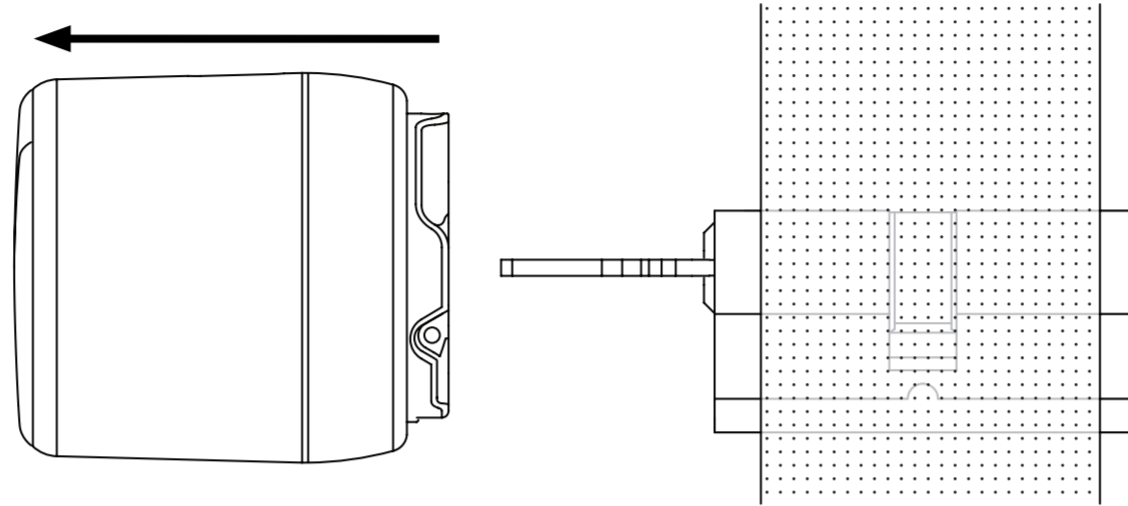

3

Heat the adapter with a hair dryer for 10-15 minutes and try to remove it with a flathead screwdriver. If unsuccessful, repeat the process until the adapter is removed.

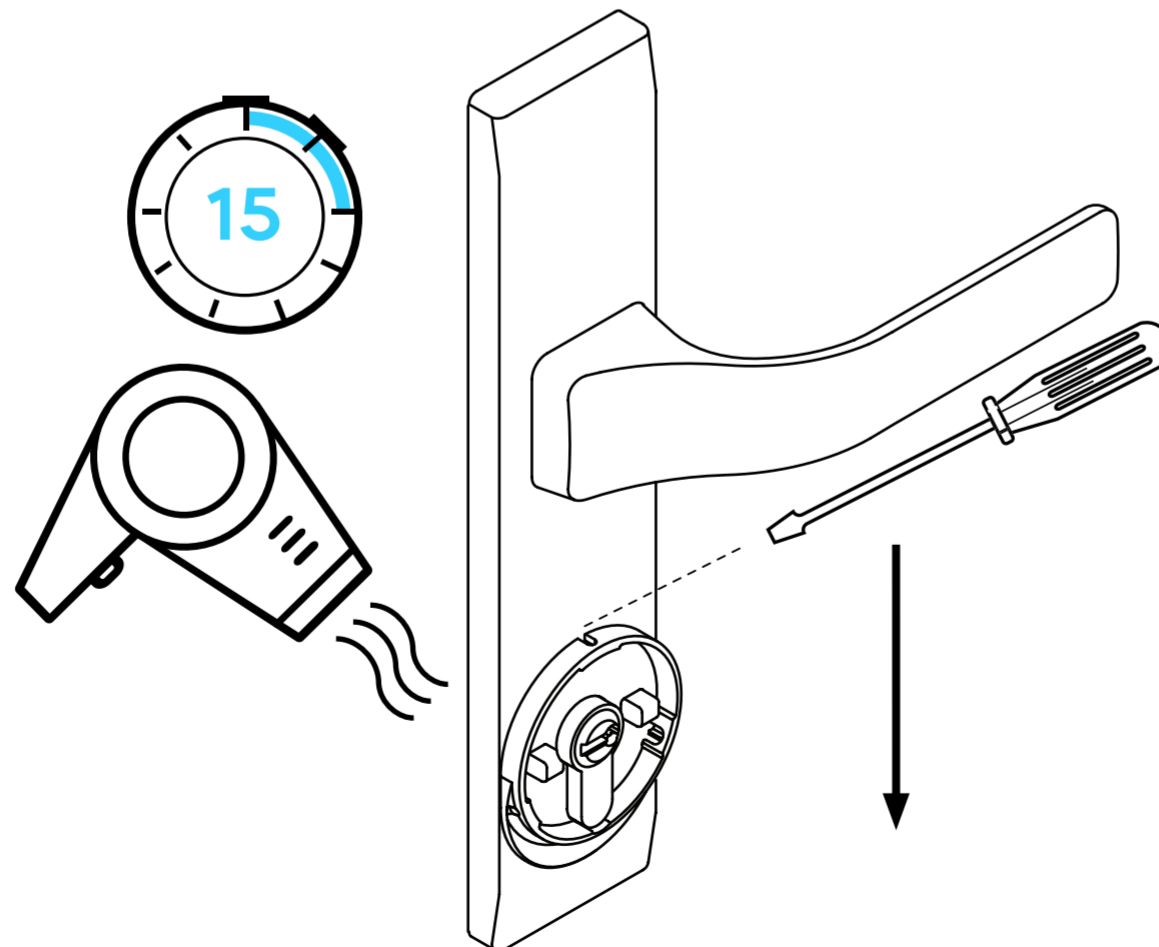

BATTERY REPLACEMENT

1

Press the latch button firmly while pulling off the cover.

2

Remove old batteries and replace them with three new batteries/rechargeable batteries according to the polarity symbols indicated on the housing.

IMPORTANT:

1) When replacing the batteries in the device, use only one type of battery. Do not mix batteries with rechargeable batteries

2) If replacing batteries with rechargeable batteries or vice versa, update the current power type in the Tedee app (Device / Settings / Battery)

3) Use 3V batteries or 3.7 V rechargeable batteries only!

3

Slide the cover back onto the housing, holding the latch button down until it clicks into place.

NOTE: After battery replacement follow the auto-calibration steps (Device / Settings / Calibration).

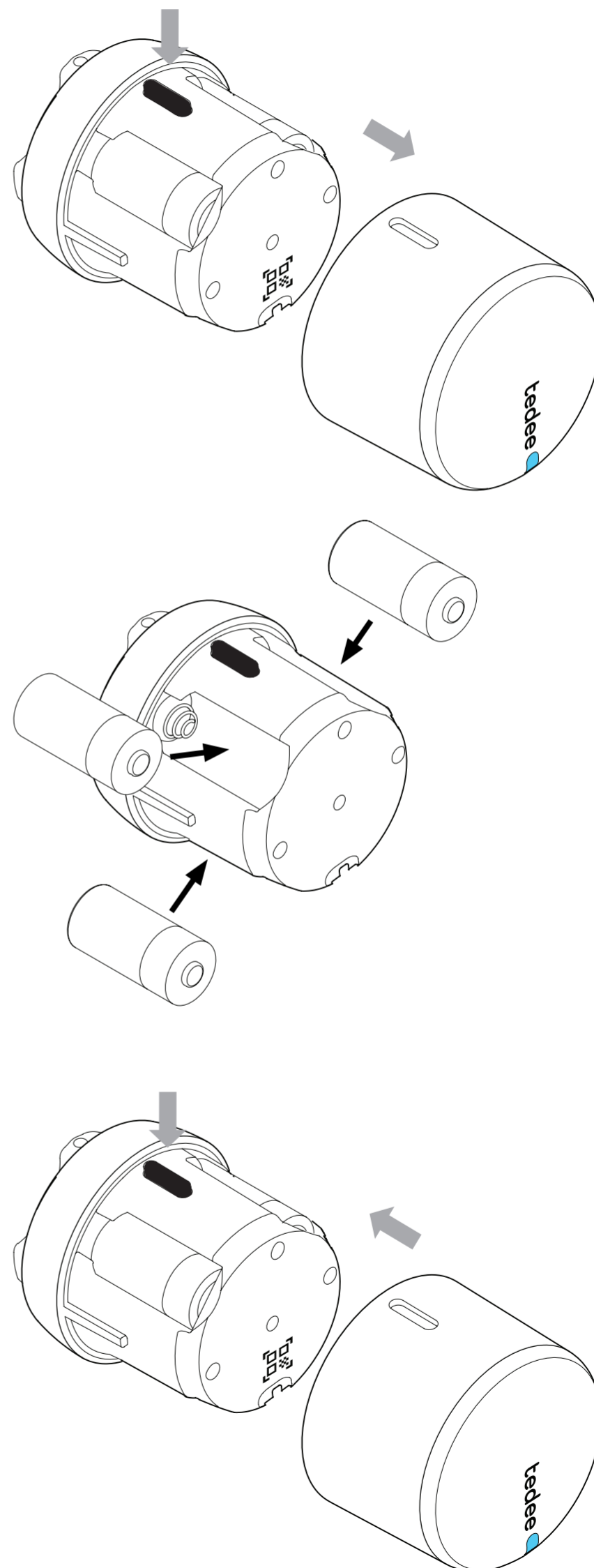

FACTORY RESET

- Remove Tedee lock from the cylinder and place it in the vertical position (button up).
- Press and hold the button until the LED lights up in RED.
- Release the button immediately after the LED turns RED.
- After releasing the button, Tedee lock will confirm the factory reset with three quick red flashes.
- Wait until the lock restarts (it may take up to one minute).

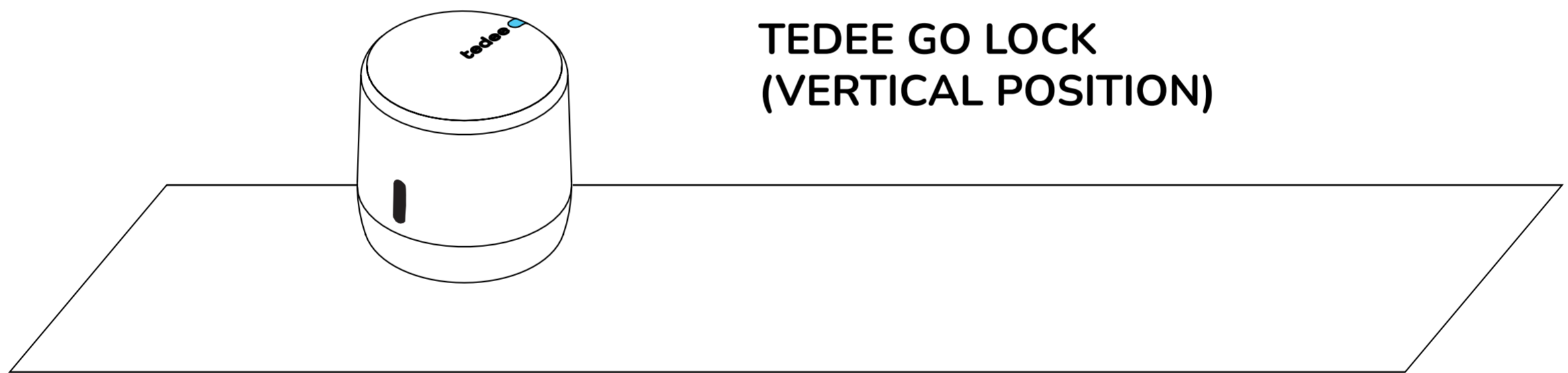

Note: Remember to position your Tedee GO lock vertically (button up).

ADDITIONAL AND TECHNICAL INFORMATION

TECHNICAL SPECIFICATIONS

Models	TLV2.0	Power supply	3x CR123/CR123A battery
Weight	ca. 196g	Bluetooth® communication	BLE 5.0 2,4GHz Applies to: TLV2.0
Dimensions	fi 58mm x 65mm		
Operating temperature	10-40°C (indoor only)	Security	TLS 1.3
Operating humidity	maximum 65%	Can be paired with	Tedee bridge Tedee keypad
Origin	Poland, EU	Can be installed on	Euro-profile cylinders, equipped with double-clutch (emergency) feature Recommended: GERDA SLR modular cylinder
Production batch number	Additional information: The production batch number of your device is the first eight characters of the “Device Serial Number (S/N)” visible on the label on the package and the label on the device itself. For example, the production batch number of the device with the “Device Serial Number (S/N)” 10101010-000001 is 10101010.		
Marking of color variants	The color variant of the product is marked with a letter at the end of the model name, on the label and on the product rating plate. For example, a device with model TLV2.0 in color variant A is marked as “TLV2.0A”.		

RADIO FREQUENCY

Tedee lock TLV2.0 is equipped with Bluetooth® BLE 5.0 2,4GHz radio interface. Bluetooth® interface is used in communication between Tedee lock, Tedee bridge, and smartphones.

Radio frequency

Interface:	Frequency range:	Applies to models:
Bluetooth ® BLE 5.0 2,4 GHz	from 2,4GHz to 2,483GHz maximum output power: 10 dBm	TLV2.0

SOFTWARE

The current software version is visible in the Tedee application: device / settings / firmware version.

Tedee lock software can be updated in two ways: automatically or manually. Automatic updates are only available when the lock is connected to the Tedee bridge which is connected to the Internet via local Wi-Fi network.

If the lock is not connected to the Tedee bridge, you may update the software manually using Tedee application: device settings / general / firmware version.

Please report any problems with the application that may occur during use (such as login errors or application hangs) to Tedee technical support by email at support@tedee.com, at www.tedee.com/support or by phone at +48 22 307 72 67 Monday to Friday during business hours from 8:00 to 16:00 (CET).

LED SIGNALS

Meaning (action)	LED (color)	Signal (type)	Additional information
Initialization	Green	Flashing (fast)	LED flashes after turning on the device. It confirms initialization process and system check-up completion.
Ready	Red - Blue - Green - White	Flashing (sequential)	LED flashes after successful initialization of the device. It confirms that your Tedee lock is ready to use.
Unlocking	Green	Constant	Green LED is turned ON while unlocking (OFF if the battery level is low).
Locking	Red	Constant	Red LED is turned ON during the locking phase (OFF if the battery level is low).
Jammed	Red	5 flashes	LED flashes red when Tedee lock is jammed and needs attention. Please check if your device is calibrated correctly - if the problem persists, contact Tedee support team.
Device shutdown	Red	Pulsating light	LED flashes after 5 seconds of pressing the button and keeps pulsating until the device is shut down. It confirms the shutdown process.
Factory reset	Red	Pulsating light	The LED blinks with three quick red flashes when the button is released which confirms that the factory settings have been restored.

Low battery	Red	3 flashes x 3 times	LED flashes when battery drops below 15%. The flashing appears after every locking / unlocking operation. Your Tedee GO requires battery replacement/charging.
Delayed locking	Blue	Flashing	LED flashes fast after pressing and holding the button for at least 1 second (and no longer than 5 seconds). Available only if delayed locking option is ON in the Tedee app.
Calibration	Blue	Flashing	LED flashes blue during the calibration phase.
Error	Red	Flashing (fast / slow)	Please contact Tedee support team.

EU Declaration of Conformity

Tedee Sp. z o.o. hereby declares that the Tedee Lock TLV2.0 radio device is in accordance with Directive 2014/53/EU. The full text of the EU Declaration of Conformity is available at the following internet address: <https://tedee.com/declaration-of-conformity/>

WEEE / RoHS

To prevent potential negative impact on the environment, consult your local laws and regulations for the proper disposal of electronic devices and batteries in your country. Disposal of batteries – if your Tedee device contains batteries, do not dispose them with regular household waste. Hand them over to the appropriate recycling or collection point. Batteries used in Tedee devices do not contain mercury, cadmium, or lead above the levels specified in 2006/66/EC Directive. Disposal of electronics - do not dispose your Tedee device with regular household waste. Hand it over to the appropriate recycling or collection point.

Bluetooth®

The Bluetooth® word mark and logos are owned by the Bluetooth SIG, Inc. and any use of such marks by Tedee Sp. z o. o. is under licence. Other trademarks and trade names are those of their respective owners.

Google, Android and Google Play are trademarks of Google LLC.

Apple and App Store are trademarks of Apple Inc. IOS is a trademark or registered trademark of Cisco in the U.S. and other countries and is used under license.

WARRANTY

Tedee limited hardware warranty - Tedee Sp. z o. o. warrants that Tedee devices are free from hardware defects in materials and workmanship for the period of not less than 2 years from the date of the first retail purchase. Tedee Sp. z o. o. does not take responsibility for the misuse of devices (including methods of charging other than described in this manual), especially if any changes or modifications to the device hardware or software which are not approved, recommended, or provided by tedee, have been undertaken by the user. Full warranty information is available at the following link: www.tedee.com/warranty



support@tedee.com



www.tedee.com/support

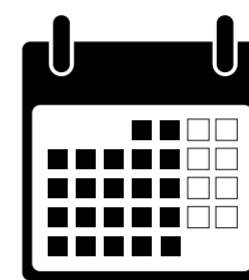

(+48) 22 307 72 67
8.00 - 16.00 (CET)

tedee

Tedee Sp. z o. o.
Karola Bohdanowicza 21/57
02-127 Warszawa
Poland